

Open Division

1o	Clapham
2o	Chevron Action Flash
3o	Fire of London
4o	PELT Ultimate
5o	Devon
6o	EMO
7o	Manchester
8o	Ranelagh
9o	Ka-Pow!
10o	Flump
11o	LLLeeds
12o	Alba
13o	Reading
14o	Brighton City
15o	Brighton Legends
16o	SMOG

A	Seed	Team	W	L
A1	1o	Clapham		
A2	8o	Ranelagh		
A3	9o	Ka-Pow!		
A4	16o	SMOG		

B	Seed	Team	W	L
B1	2o	Chevron Action Flash		
B2	7o	Manchester		
B3	10o	Flump		
B4	15o	Brighton Legends		

C	Seed	Team	W	L
C1	3o	Fire of London		
C2	6o	EMO		
C3	11o	LLLeeds		
C4	14o	Brighton City		

D	Seed	Team	W	L
D1	4o	PELT Ultimate		
D2	5o	Devon		
D3	12o	Alba		
D4	13o	Reading		

E	Seed	Team	W	L
E1	1o			
E2	3o			
E3	6o			
E4	8o			

F	Seed	Team	W	L
F1	2o			
F2	4o			
F3	5o			
F4	7o			

G	Seed	Team	W	L
G1	9o			
G2	11o			
G3	14o			
G4	16o			

H	Seed	Team	W	L
H1	10o			
H2	12o			
H3	13o			
H4	15o			

Seeding & Pools

Mixed Division

1x	Reading Ultimate
2x	Black Eagles
3x	JR
4x	Deep Space
5x	SMOG
6x	Glasgow Ultimate
7x	Dublin Gravity
8x	Mighty Hucks

J	Seed	Team	W	L
J1	1x	Reading Ultimate		
J2	3x	JR		
J3	6x	Glasgow Ultimate		
J4	8x	Mighty Hucks		

K	Seed	Team	W	L
K1	2x	Black Eagles		
K2	4x	Deep Space		
K3	5x	SMOG		
K4	7x	Dublin Gravity		

Women's Division

1w	Iceni
2w	Nice Bristols
3w	SYC
4w	Brighton
5w	LLLeeds
6w	Rebel
7w	Chaos
8w	Reading

L	Seed	Team	W	L
L1	1w	Iceni		
L2	3w	SYC		
L3	6w	Rebel		
L4	8w	Reading		

M	Seed	Team	W	L
M1	2w	Nice Bristols		
M2	4w	Brighton		
M3	5w	LLLeeds		
M4	7w	Chaos		

Monday

Pitch	1	2	3	4	5	6	7	8	9	10	11	12	x	Pitch
09:00 10:30	O 2v3		O 1v4		O 9v12	O 10v11	O 6v7	O 5v8	O 13v16	O 14v15				09:00 10:30
10:50 12:20	O 3v5		O 4v6		O 9v10	O 11v12		O 7v8	O 13v14	O 15v16				10:50 12:20
12:40 14:10	O 1v2													12:40 14:10
14:30 16:00	O 3v4		O 5v6											14:30 16:00
16:20 17:50														16:20 17:50



Formats

Women's division:

1-8 in 2 powerpools of 4

Semis 1-4, 5-8

Recovery games 3-6, then finals 1-8

Mixed division:

1-8 in 2 powerpools of 4

Semis 1-4, 5-8

Recovery games 3-6, then finals 1-8

Open division:

1-16 in pools of 4

1-8, 9-16 in powerpools of 4 (carrying a result)

Crossover 5-12

Semis 1-4, 5-8, 9-12, 13-16

Recovery games 3-6, then finals 1-16

Switching Bracket Games

In certain 'parallel' games, it may sometimes be possible to switch the lower seeded teams to prevent rematches. E.g., if 3v5 or 4v6 in these Nationals schedules were to be a rematch, and swapping 5&6 would remove any rematches, then we should switch them. The exact rule we will follow for any parallel games is below.

- 1) *Examine the regularly scheduled matchups and determine whether either game is a rematch of a game which occurred earlier in BRACKET play. If so, continue to step 2, otherwise skip to step 3.*
(For the purposes of this procedure, all games after the conclusion of pool play are considered bracket games.)
- 2) *Consider the matchups that would occur if the lower-seeded teams (that is, the teams that were already in the sub-bracket in the previous round) were switched. If either of the resulting games would be rematches of BRACKET play, then the procedure is complete and no changes should be made to the schedule. Otherwise, go to step 5.*
- 3) *Examine the regularly scheduled matchups and determine whether either game is a rematch of a game which occurred earlier in POOL play. If so, continue to step 4, otherwise the procedure is complete and no changes should be made to the schedule.*
- 4) *Consider the matchups that would occur if the lower-seeded teams were switched. If either of the resulting games would be rematches of earlier games in the tournament (either in pool play or bracket play), then the procedure is complete and no changes should be made to the schedule. Otherwise, continue to step 5.*
- 5) *Switch the lower-seeded teams, so that they now play the opposite opponents.*

Game Rules

All games will be played according to WFDF Rules of Ultimate 2017.

All games

90 minutes, game to 15, 2 minute half at 8. Two time-outs per team per half. A hooter will signal the start and end of the game.

When time is up, finish the point then reduce points target to current highest score +1, but never exceed the original target

Time-outs may be taken in the cap, which forms part of the second half.

Late Arrival

If your opponent is late for the game without good reason, they will be given 5 minutes grace and then the team that was on time will assess a point against them, plus another point for every 2 additional minutes (until they are ready to play, or the point cap is reached).

This will not apply if the team is late for reasons such as errors in the schedule, or bad information from TDs, or previous games overrunning -

but may apply if they had themselves made an error reading the schedule or had been stuck in traffic etc. UKU or the TDs will rule on any unclear situations.

Teams without an opponent should be aware that they are obliged to try and find them and to notify the TDs - it is not acceptable to sit there quietly and hope to win by forfeit.

Hard Cap - IGNORE UNLESS SPECIFICALLY TOLD OTHERWISE

In case of strong wind making scoring hard, we do need a way to finish games.

In good weather, we expect any overruns to be very rare and these rules will NOT apply.

In bad weather, however, we run the risk of too many games struggling to finish, and we need rules to enable us to cope.

These rules, if and only if implemented, would apply to ALL GAMES.

These rules may be implemented in advance, or part way through the day due to deteriorating weather. We will endeavour (but do not guarantee) to inform teams in person, and will of course communicate through the usual channels (i.e. @ukultimateevent on Twitter, and notices at the TD desk).

- 1) Hard cap will apply immediately when the hooter sounds to START the next game
- 2) Finish the possession.
- 3) ONLY if the game is tied, finish the point.
- 4) No time-outs in hard cap
- 5) The subsequent game may be shortened by up to 5 mins to accommodate the finish, or may be moved to an empty pitch (or self-timed if delayed by more than 5 minutes and no spare pitch is available)
- 6) Obviously the TDs also reserve the right to make additional decisions on the day - e.g. if no point has been scored for a very long time, a resolution must be found, particularly if the teams involved are playing a back-to-back game afterwards. That may mean agreeing a draw in pool play, or finding another method of settling a knockout game. We hope that will never happen - but it might!

A	Team	Score	v	Score	Team	
A1vA3	Clapham		v		Ka-Pow!	<i>Saturday, 09:00 - Pitch 9</i>
A2vA4	Ranelagh		v		SMOG	<i>Saturday, 09:00 - Pitch 10</i>
A1vA2	Clapham		v		Ranelagh	<i>Saturday, 12:40 - Pitch 5</i>
A3vA4	Ka-Pow!		v		SMOG	<i>Saturday, 12:40 - Pitch 6</i>
A1vA4	Clapham		v		SMOG	<i>Saturday, 16:20 - Pitch 2</i>
A2vA3	Ranelagh		v		Ka-Pow!	<i>Saturday, 16:20 - Pitch 4</i>

Final Standings

1A	1o	
2A	8o	
3A	9o	
4A	16o	

B	Team	Score	v	Score	Team	
B1vB3	Chevron Action Flash		v		Flump	<i>Saturday, 09:00 - Pitch 11</i>
B2vB4	Manchester		v		Brighton Legends	<i>Saturday, 09:00 - Pitch 12</i>
B1vB2	Chevron Action Flash		v		Manchester	<i>Saturday, 12:40 - Pitch 1</i>
B3vB4	Flump		v		Brighton Legends	<i>Saturday, 12:40 - Pitch 7</i>
B1vB4	Chevron Action Flash		v		Brighton Legends	<i>Saturday, 16:20 - Pitch 7</i>
B2vB3	Manchester		v		Flump	<i>Saturday, 16:20 - Pitch 8</i>

Final Standings

1B	2o	
2B	7o	
3B	10o	
4B	15o	

C	Team	Score	v	Score	Team	
C1vC3	Fire of London		v		LLLeeds	<i>Saturday, 09:00 - Pitch 7</i>
C2vC4	EMO		v		Brighton City	<i>Saturday, 09:00 - Pitch 8</i>
C1vC2	Fire of London		v		EMO	<i>Saturday, 12:40 - Pitch 3</i>
C3vC4	LLLeeds		v		Brighton City	<i>Saturday, 12:40 - Pitch 4</i>
C2vC3	EMO		v		LLLeeds	<i>Saturday, 16:20 - Pitch 12</i>
C1vC4	Fire of London		v		Brighton City	<i>Saturday, 16:20 - Pitch 11</i>

Final Standings

1C	3o	
2C	6o	
3C	11o	
4C	14o	

D	Team	Score	v	Score	Team	
D1vD3	PELT Ultimate		v		Alba	<i>Saturday, 09:00 - Pitch 4</i>
D2vD4	Devon		v		Reading	<i>Saturday, 09:00 - Pitch 2</i>
D1vD2	PELT Ultimate		v		Devon	<i>Saturday, 12:40 - Pitch 12</i>
D3vD4	Alba		v		Reading	<i>Saturday, 12:40 - Pitch 11</i>
D1vD4	PELT Ultimate		v		Reading	<i>Saturday, 16:20 - Pitch 6</i>
D2vD3	Devon		v		Alba	<i>Saturday, 16:20 - Pitch 5</i>

Final Standings

1D	4o	
2D	5o	
3D	12o	
4D	13o	

Open Pools

Open Powerpools

E	Team Score		Score	Team	
E1vE4			v		Carried Over
E2vE3			v		Carried Over
E1vE3			v		Sunday, 08:45 - Pitch 5
E2vE4			v		Sunday, 08:45 - Pitch 6
E1vE2			v		Sunday, 12:25 - Pitch 4
E3vE4			v		Sunday, 12:25 - Pitch 5

Final Standings		
1E	1o	
2E	3o	
3E	6o	
4E	8o	

F	Team Score		Score	Team	
F1vF4			v		Carried Over
F2vF3			v		Carried Over
F1vF3			v		Sunday, 08:45 - Pitch 9
F2vF4			v		Sunday, 08:45 - Pitch 10
F1vF2			v		Sunday, 12:25 - Pitch 8
F3vF4			v		Sunday, 12:25 - Pitch 9

Final Standings		
1F	2o	
2F	4o	
3F	5o	
4F	7o	

G	Team Score		Score	Team	
G1vG4			v		Carried Over
G2vG3			v		Carried Over
G1vG3			v		Sunday, 08:45 - Pitch 11
G2vG4			v		Sunday, 08:45 - Pitch 12
G1vG2			v		Sunday, 12:25 - Pitch 10
G3vG4			v		Sunday, 12:25 - Pitch 11

Final Standings		
1G	9o	
2G	11o	
3G	14o	
4G	16o	

H	Team Score		Score	Team	
H1vH4			v		Carried Over
H2vH3			v		Carried Over
H1vH3			v		Sunday, 08:45 - Pitch 7
H2vH4			v		Sunday, 08:45 - Pitch 8
H1vH2			v		Sunday, 12:25 - Pitch 6
H3vH4			v		Sunday, 12:25 - Pitch 7

Final Standings		
1H	10o	
2H	12o	
3H	13o	
4H	15o	

J	Team	Score	v	Score	Team	
J2vJ4	JR		v		Mighty Hucks	<i>Saturday, 10:50 - Pitch 10</i>
J1vJ3	Reading Ultimate		v		Glasgow Ultimate	<i>Saturday, 10:50 - Pitch 9</i>
J2vJ3	JR		v		Glasgow Ultimate	<i>Saturday, 14:30 - Pitch 7</i>
J1vJ4	Reading Ultimate		v		Mighty Hucks	<i>Saturday, 14:30 - Pitch 8</i>
J1vJ2	Reading Ultimate		v		JR	<i>Saturday, 16:20 - Pitch 1</i>
J3vJ4	Glasgow Ultimate		v		Mighty Hucks	<i>Saturday, 16:20 - Pitch 3</i>

Final Standings

1J	1x	
2J	3x	
3J	6x	
4J	8x	

K	Team	Score	v	Score	Team	
K1vK3	Black Eagles		v		SMOG	<i>Saturday, 10:50 - Pitch 1</i>
K2vK4	Deep Space		v		Dublin Gravity	<i>Saturday, 10:50 - Pitch 3</i>
K2vK3	Deep Space		v		SMOG	<i>Saturday, 14:30 - Pitch 10</i>
K1vK4	Black Eagles		v		Dublin Gravity	<i>Saturday, 14:30 - Pitch 9</i>
K3vK4	SMOG		v		Dublin Gravity	<i>Saturday, 16:20 - Pitch 10</i>
K1vK2	Black Eagles		v		Deep Space	<i>Saturday, 16:20 - Pitch 9</i>

Final Standings

1K	2x	
2K	4x	
3K	5x	
4K	7x	

L	Team	Score	v	Score	Team	
L2vL4	SYC		v		Reading	<i>Saturday, 09:00 - Pitch 1</i>
L1vL3	Iceni		v		Rebel	<i>Saturday, 09:00 - Pitch 3</i>
L1vL2	Iceni		v		SYC	<i>Saturday, 10:50 - Pitch 7</i>
L3vL4	Rebel		v		Reading	<i>Saturday, 10:50 - Pitch 8</i>
L2vL3	SYC		v		Rebel	<i>Saturday, 14:30 - Pitch 11</i>
L1vL4	Iceni		v		Reading	<i>Saturday, 14:30 - Pitch 12</i>

Final Standings

1L	1w	
2L	3w	
3L	6w	
4L	8w	

M	Team	Score	v	Score	Team	
M2vM4	Brighton		v		Chaos	<i>Saturday, 09:00 - Pitch 5</i>
M1vM3	Nice Bristols		v		LLLeeds	<i>Saturday, 09:00 - Pitch 6</i>
M3vM4	LLLeeds		v		Chaos	<i>Saturday, 10:50 - Pitch 5</i>
M1vM2	Nice Bristols		v		Brighton	<i>Saturday, 10:50 - Pitch 6</i>
M2vM3	Brighton		v		LLLeeds	<i>Saturday, 14:30 - Pitch 1</i>
M1vM4	Nice Bristols		v		Chaos	<i>Saturday, 14:30 - Pitch 3</i>

Final Standings

1M	2w	
2M	4w	
3M	5w	
4M	7w	

Mixed

Women's

Women's

1

Pitch 3, Sunday 10:35

4

3

Pitch 1, Sunday 10:35

2

1

Pitch 1, Sunday 17:35

2

1

2



UKU

UK Ultimate Ltd www.ukultimate.com

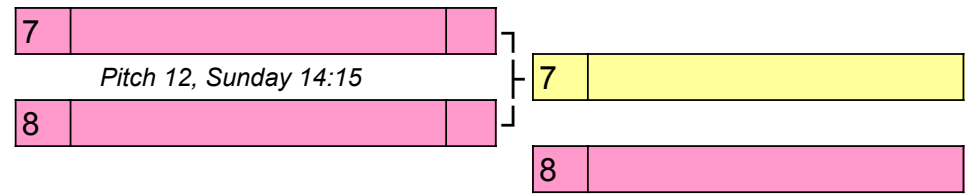
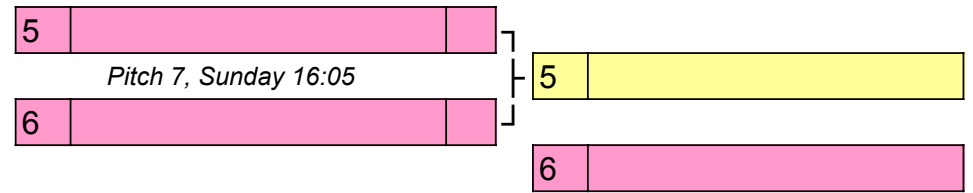
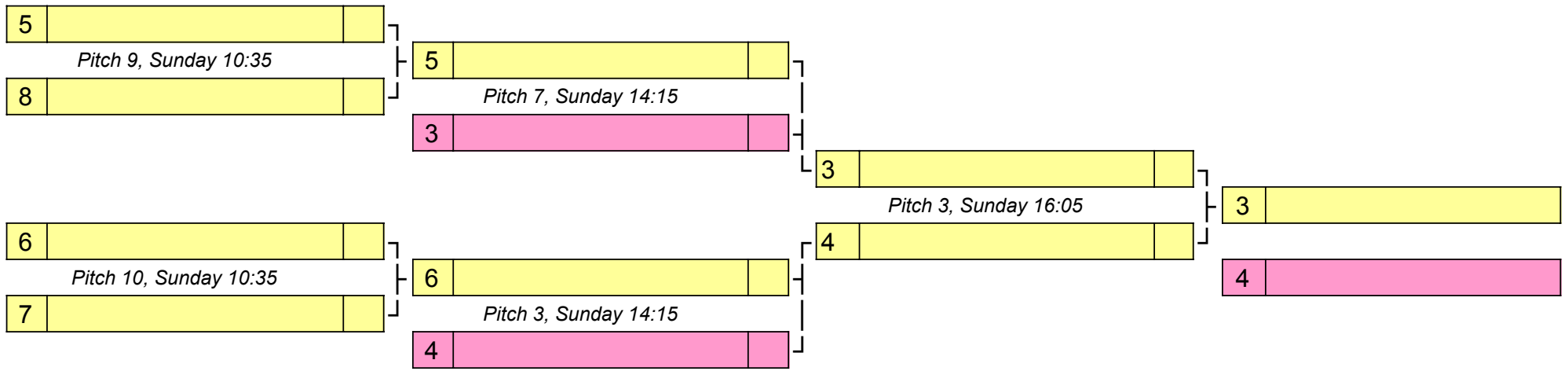

Women's

1

Pitch 3, Sunday 08:45

4

Mixed

3

Pitch 1, Sunday 08:45

2

1

Pitch 1, Sunday 15:45

2

1

2



UKU

UK Ultimate Ltd www.ukultimate.com

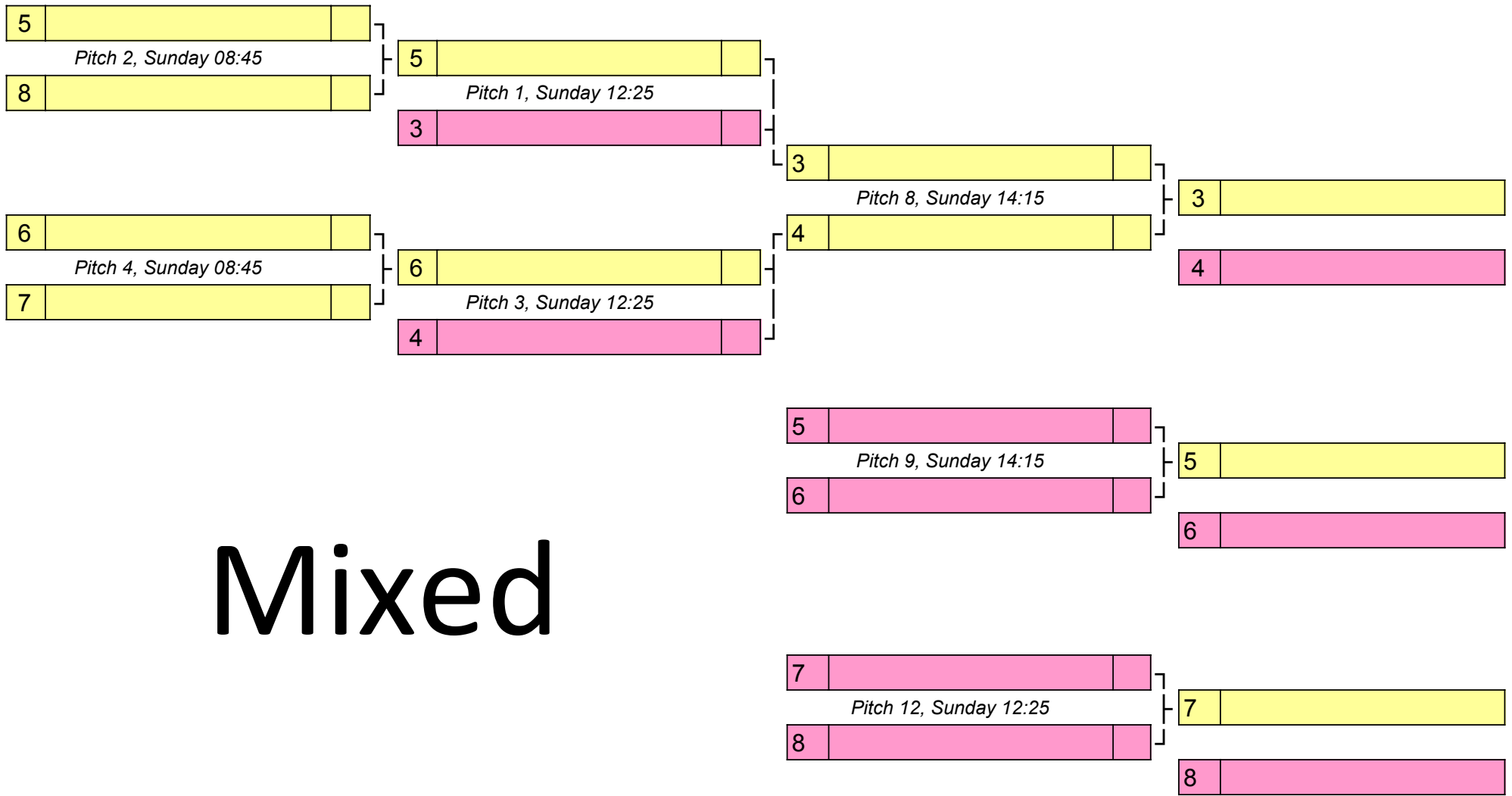

Mixed

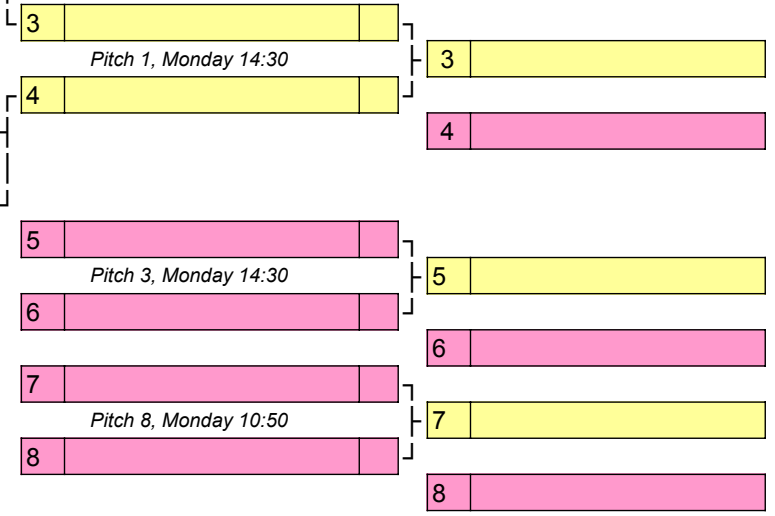
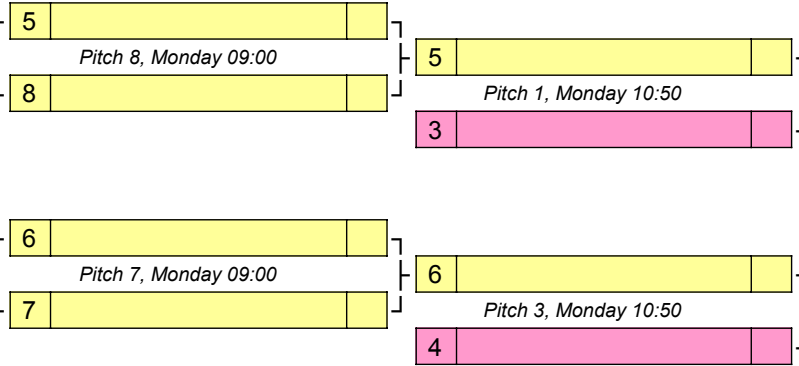
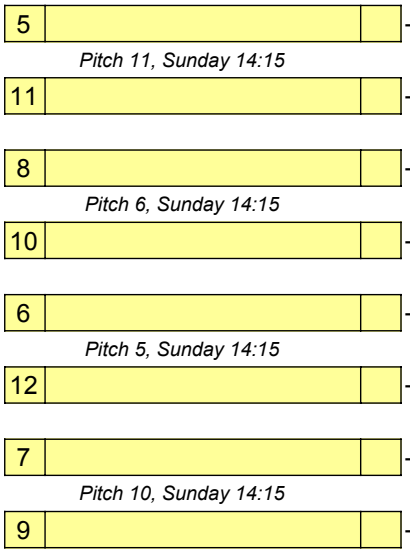
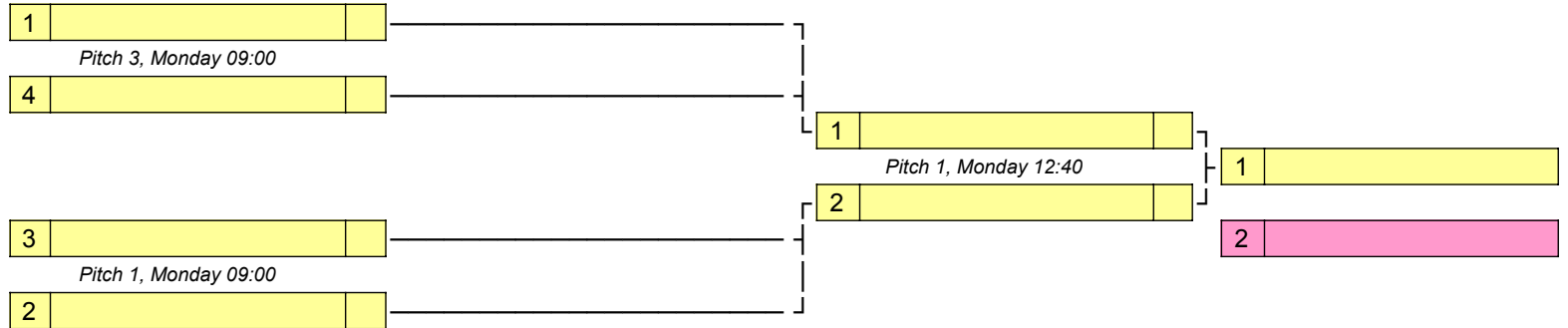

Open

